

SON4L Alarm Sounder & LED Beacon

The SON4L is a compact, high output, 100dB(A) alarm sounder with integral L.E.D. array beacon.

The robust fire retardant housing ensures the SON4L is suitable for all general signalling applications including fire, security and process control.

Features

- Automatic synchronisation on multi-sounder system.
- Continuously rated.
- Stainless steel fixings.
- Duplicate cable terminations (in & out for daisy-chain installations).
- Tropicalisation available on request.
- Available with custom tone configurations and frequencies.

Approvals

- VdS approved: EN54-3 (CPD 89/106/EEC).
- GOST-R approved. Cert: POCC GB-JB05-H00144.



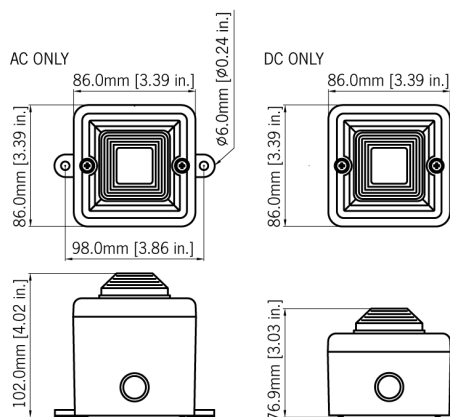

Specification

Sounder:	
Maximum output:	100dB(A) @ 1 metre [91dB(A) @ 10ft/3m]
Nominal output:	99dB(A) @ 1m +/- 3dB - Tone 1 [90dB(A) @ 10ft/3m]
No. of tones:	10 (UK00A / PFEER compliant)
No. of stages:	3
Volume control:	On board potentiometer
Effective range:	30m/99ft @ 1KHz
Stage switching:	Negative
Beacon:	
Light source:	5 x high intensity L.E.D. array
Flash rate:	2 Hz
Peak/Effective Intensity cd:	3cd* - measured ref. to I.E.S.
Lens / L.E.D.:	Amber & Red
General:	
Voltages DC:	12V dc; 24V dc; 48V dc
Voltages AC:	24V ac; 115V ac; 230V ac
Ingress protection:	IP66
Housing material:	High impact UL94 V0 & 5VA FR ABS
Colour:	Red (RAL3000), grey (RAL7038) & white.
Lens material:	PC
Cable entries:	4 x M20 clearance gland knockouts in side & back
Terminals:	0.5 to 1.5mm ² cables.
Operating temp:	-25 to +55°C [-13° to +131°F]
Storage temp:	-40 to +70°C [-40° to +158°F]
Relative humidity:	90% at 20°C [68°F]
Weight:	DC: 0.30kg/0.66lbs AC:0.40kg/0.88lbs
*SPL data +/-3dB(A). Measured at optimum voltage.	
*Candela measurements representative of performance with amber lens at optimum voltage.	

Part Codes

|_ .Version: |_ .Part code: | | 12V dc | SON4LDC12[x]/[y] | | 24V dc | SON4LDC24[x]/[y] | | 48V dc | SON4LDC48[x]/[y] | | 24V ac | SON4LAC24[x]/[y] | | 115V ac | SON4LAC115[x]/[y] | | 230V ac | SON4LAC230[x]/[y] | | [x] = Enclosure colour: | G: Grey (RAL7038) | R: Red (RAL3000) | W: White | | [y] = Lens colour: | A: Amber | R: Red |

Tone table

S 1	Description	S 2	S 3
T 2	500/1200Hz @ 0.3Hz 0.5 sec Slow Whoop	T 1	T 8
T 3	1200/500Hz @ 1Hz - DIN / PFEER P.T.A.P.	T 1	T 8
T 4	544Hz (100mS)/440Hz (400mS) - NF S 32-001	554Hz	T 2
T 5	1000Hz Continuous - PFEER Toxic Gas	T 1	T 6
T 6	Bell	T 1	T 8
T 7	800/1000Hz @ 7Hz Sweeping	T 5	T 1
T 8	2400/2900Hz @ 50Hz Sweeping	T 5	T 1
T 9	420Hz @ 0.625 sec Australian Alert	T 10	T 5
T 10	500-1200Hz 3.75sec /0.25sec. Australian Evac.	T 6	T 5